

Technical Description

LabEvent T/20/40/3



LabEvent T/20/40/3 01.2E/04 2018

Contents.

	Page
Highlights at a glance.....	3
Standards.....	4
Performance data.....	5
Temperature tests.....	5
Cooling and heating performance.....	6
Heat compensation performance curve.	6
Technical Data.....	7
Dimensions and weights.	7
Technical data for installation.....	7
Installation drawing.....	8
Our basic equipment.	9
Definitions and Notes.....	11
Optional Accessories.	12
Your additional equipment.....	14

Highlights at a glance.

- **Operating/programming and monitoring unit with 18 cm (7") web panel**
- **New, eco-friendly refrigerant R449A with low GWP**
- **Modern Design**
- **Remote control and monitoring via intranet or internet**
- **Ethernet 100/1000 Megabit**
- **Handy size thanks to a compact design**

LabEvent T/20/40/3

Ordering code: 67842005

Standards.

Low temperature test

- IEC 60068-2-1, Test A
- IEC 60721-4
- ISO 16750-4, Low temperature
- ETSI EN 300019-2-4, Test Ab/Ad
- MIL-STD-331 C, Test C6
- MIL-STD-810 G, Meth. 502.5
- MIL-E-5272, Teil 4.2
- JESD22-A119

Alternating temperature test

- IEC 60068-2-14, Test Nb
- IEC 60721-4,
- ISO 16750-4, Temp. steps
- ISO 16750-4, Temp. Cycling
- ETSI EN 300019-2-4, Test Nb
- MIL-STD-331 C, Test C6

High temperature tests

- IEC 60068-2-2, Test B
- IEC 60721-4
- ISO 16750-4, High temperature
- ETSI EN 300019-2-4, Test Bb/Bd
- MIL-STD-202 G, Meth. 108A
- MIL-STD-331 C, Test C6
- MIL-STD-810 G, Meth. 501.5
- MIL-STD-883 J, Meth. 1008.2
- MIL-E-5272, Teil 4.1
- JESD22-A103D

The temperature values specified in the standards (severity levels) are limited by the highest and lowest test space temperature. The choice of the appropriate test system depends on the temperature change rates during alternating tests. The requirements are met if the test system capacity is large enough to compensate for the influence of the specimen and its heat dissipation in the relevant capacity range. Please contact us to test the feasibility with your test specimen.

The reference point for test values and tolerance specifications is the middle of the test space. Verifying documentation for individual test values is optionally available at additional cost.

Your standard is not listed? Contact us!

Performance data.

Temperature tests.

Temperature range	-40 °C to +130 °C
Average temperature rate of change according to IEC 60068-3-5	Heating: 5.0 K/min Cooling: 4.0 K/min
Temperature deviation in time, in centre of working space	± 0.3 K to ± 1.0 K
Temperature homogeneity in space relative to the set value ¹	± 0.5 K to ± 2.0 K
Heat compensation at +20 °C	240 W
Temperature calibration values are measured at ²	-25 °C and +80 °C

We reserve the right to make any technical changes without prior notice.

¹ at temperature range -40 °C to +100 °C

² The factory calibration of the temperature values is carried out with DAkkS-calibrated measuring equipment in the test chamber centre and documented by means of a factory calibration certificate. Optionally, a DAkkS calibration and a spatial factory or DAkkS calibration can be performed.

Cooling and heating performance.

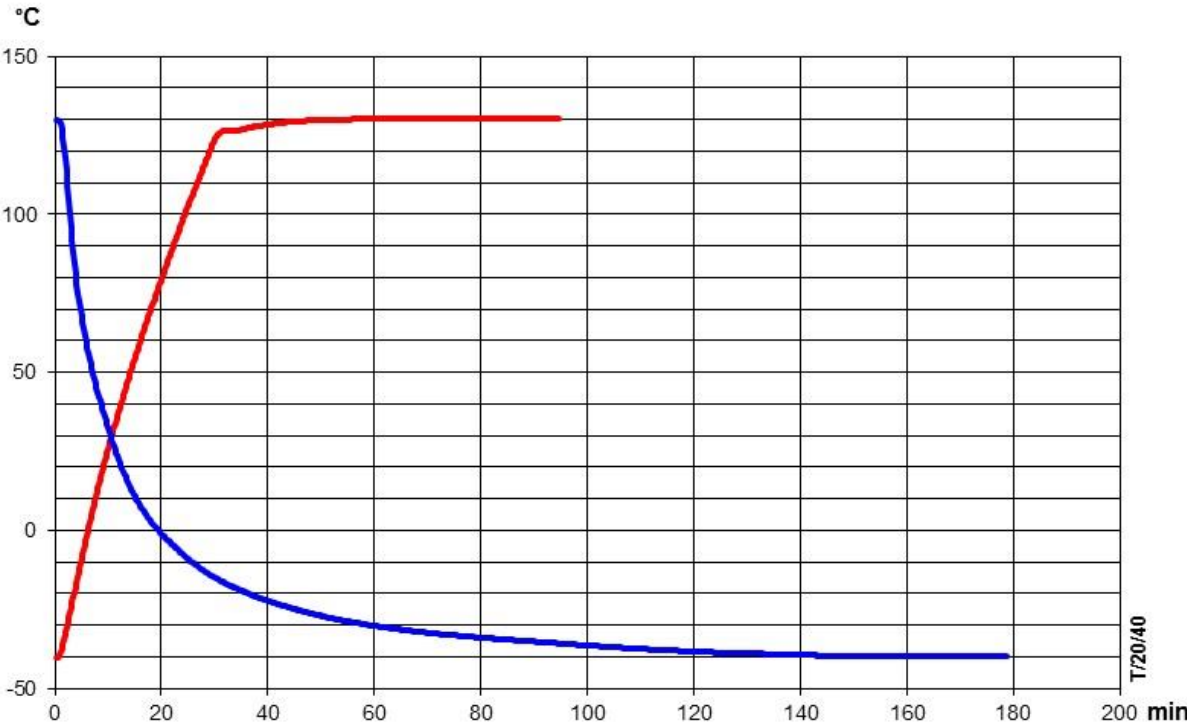

Heat compensation performance curve.

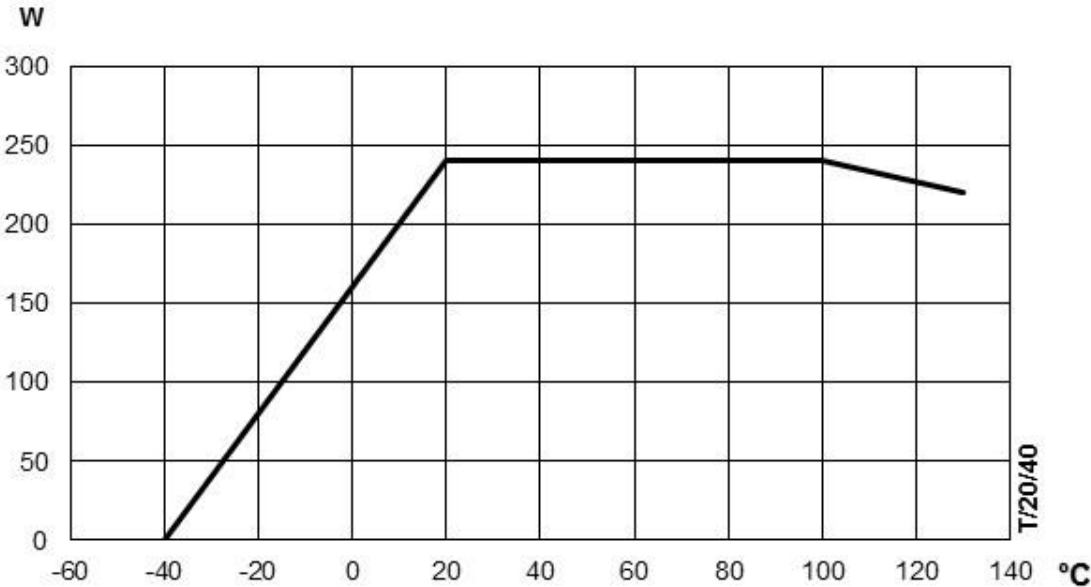

We reserve the right to make any technical changes without prior notice.

Technical Data.

Dimensions and weights.

Test space volume	approx. 16 l
Dimensions test space, H x W x D	205 mm x 310 mm x 230 mm
Exterior housing dimensions, H x W x D	625 mm x 470 mm x 570 mm
Weight	approx. 60 kg netto

Technical data for installation.

Operating conditions	ambient temperature: +10 °C to +35 °C; max. rel. air humidity 75 % r. h.; max. dew point +20 °C
Installation conditions	Please protect test chamber against direct sunlight and sources of heat.
Heat dissipation to installation space	max. approx. 1.0 kW
Sound pressure level	approx. 52 dB(A) measured in 1 m distance from the front and in 1.6 m height at free field measurement according to EN ISO 11201.

Electrical:

Nominal voltage	1/N/PE AC 230V ±10% 50Hz
Nominal power	approx. 0.7 kW
Nominal current	approx. 4 A
Connector	Schuko
Connection cable	approx. 3.5 m
Fuse protection	16 A slow blow, customer provided

Protection class	electrical compartment: IP 20 control unit: IP 54
------------------	--

Energy consumption at -20 °C	approx. 4.8 kWh / 24h
---------------------------------	-----------------------

We reserve the right to make any technical changes without prior notice.

Installation drawing.

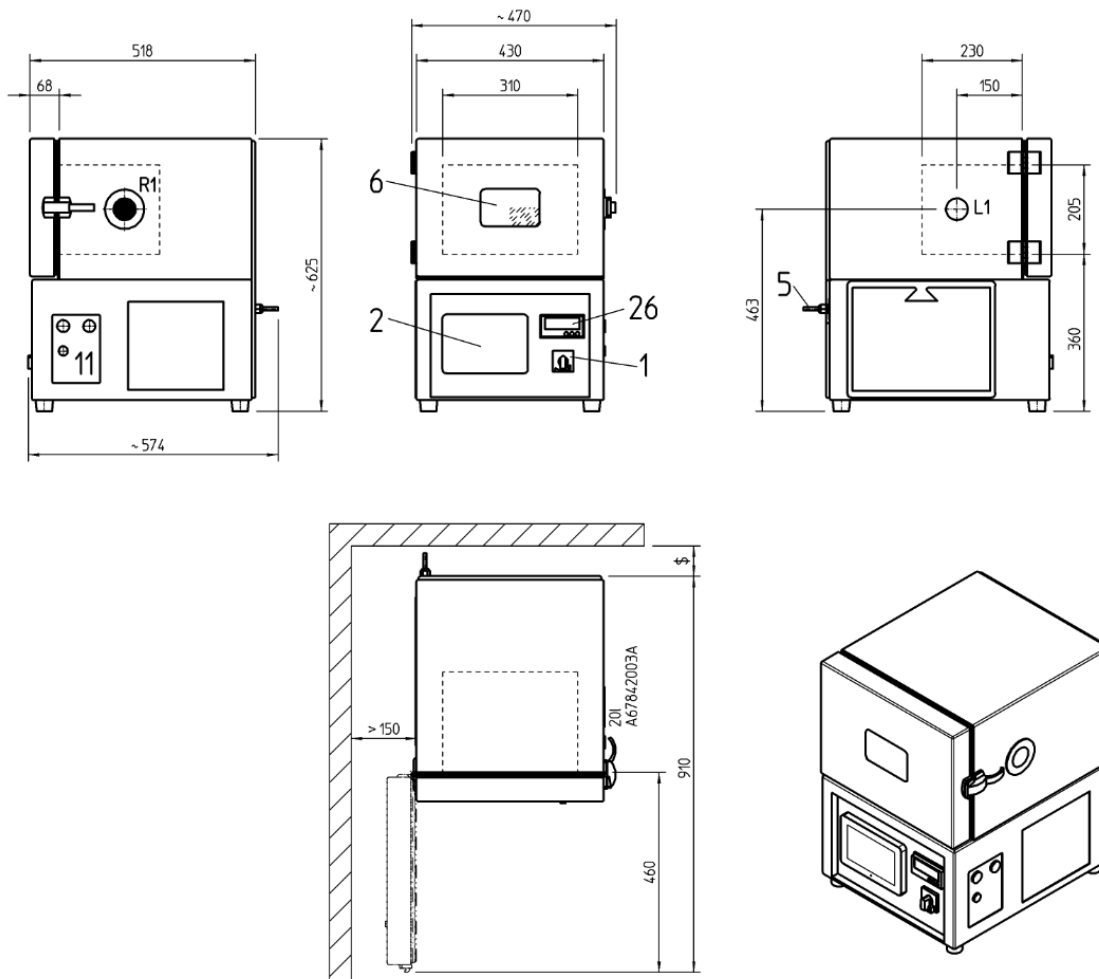

- | | | |
|---|----|---|
| R1 Ø 50 mm (Port installed in basic equipment) | 6 | Door with window) |
| L1 Additional installation positions left (additional equipment) | 11 | Connector field |
| 1 | 26 | Independent, adjustable temperature limiter |
| 2 | ~ | transport dimensions |
| 5 | \$ | escape route according to standard IEC 60364-7-729 (VDE 100 part 729) |
| | | |

We reserve the right to make any technical changes without prior notice.

Our basic equipment.

Casing	zinc plated sheet metal with resistant powder coating, colour: RAL 9002, grey-white
Door	one-hand operation, lockable, with window, hinged on the left hand side, colour: RAL 9002, grey-white
Test space	polished stainless steel, grade 1.4301 max. surface load 15 kg
Entry port	1 Entry port \varnothing 50 mm r. h. side, incl. sealing plug
Air circulation conditioning	at rear wall, with axial flow fan
Refrigeration unit	air-cooled refrigeration unit with continuously variable power adjustment by SIMPAC® and CFC-free refrigeration cycle
Refrigerant	chloride-free refrigerant R449A without ozone depletion potential, R449A, GWP: 1397, fill quantity: 0.7 kg CO ₂ equivalent: 1.0 t

We reserve the right to make any technical changes without prior notice.

Regulation and control (SIMPAC®)

WEBSeason®

Web based measuring and control system with I/O unit and WEBSeason®-software

Operating/programming and monitoring unit with 18 cm (7") web panel



Control

Highly efficient 32 bit control and monitoring system SIMPAC®

Test Cabinet protection

safety temperature limiter (STB) for protection of the test cabinet against overheating

Switching-off of test specimen

potential-free contact especially for heat emitting test specimens, lead onto socket, max. load 24 V, 0.5 A

Test specimen protection

independent adjustable temperature limiter t_{\min}/t_{\max} , sensor in test space installed, individually adjustable fixed values



Independent adjustable temperature limiter

USB

for external saving of measuring data per USB stick

Ethernet

100/10 megabit for integration into network or connection with customer's computer

Customer protocols

SimServ (to control the temperature test chamber via the ethernet interface)

Measuring sensors

Temperature

platinum measuring sensor Pt 100

We reserve the right to make any technical changes without prior notice.

Definitions and Notes.

The temperature accuracy mentioned is measured temporal in the centre of the test space. This is with stabilized conditions, without test specimens, without heat load and without optional accessories in the test space.

The factory calibration of the temperature values will be made by using DAkkS-DKD calibrated measuring equipment in the centre of the test space. The calibration is documented with a calibration sheet. Optionally we can offer a DAkkS-calibration as well as a spatial calibration according to factory(WKD)- or DAkkS-DKD-calibration. The DAkkS is member of EA (European co-operation for Accreditation) as well as ILAC (International Laboratory Accreditation Cooperation).

All figures are average values of the basic equipment and are valid at +25 °C ambient temperature, at a cooling water temperature of 18 °C and a nominal voltage of 230 V/50 Hz, without test specimens, without heat load and without optional accessories.

The equipment can also be connected to a 1/N/PE AC 220 V +/- 10 % 50 Hz power supply. The main difference at nominal voltage 220 V is then an approx. 10 % reduction in the heating temperature change rate.

The sensor for control is permanently installed in the exhaust air. The sensor for temperature limiting is movable.

The equipment is designed for installation in dry and aerated rooms with max. permissible air contamination according to EN 50178 class 2: 1997.

The EMC test (electromagnetic compatibility) and the statements regarding interference are according to EN 61000-6-3: 2007 / EN 61000-6-4: 2007. The interference immunity is according to EN 61000-6-2: 2005.

Test space with low emission due to application of tempered silicone components. If the test space has to be emission-free, this has to be clarified technically and can be offered on request.

Tests with temperatures $>+5$ °C can be run in continuous operation, $< +5$ °C discontinuously or with the optional accessory compressed air dryer.

The illustrations are examples of designs. Deviations resulting from technical progress are possible.

(EU) directive no. 517/2014 specifies an obligation for stationary refrigeration and air conditioning units with a CO₂ equivalent of 5 to 50 t to be checked for leaks at least annually and an equipment logbook to be kept; units with a leak detection system must be checked every 24 months. We can carry out these tasks for you in our capacity as an expert partner. We would be glad to advise you on installing a leak detection system.

Optional Accessories.

Access ports

e60888600	Access port Ø 50 mm
e64842916	Access port Ø 80 mm
e62749146	Silicone sealing plug for access port Ø 50 x 40 mm, 1 x slotted
e62749147	Silicone sealing plug for access port Ø 80 x 40 mm, 1 x slotted

Set up

e61814045	Laboratory trolley, mobile
-----------	----------------------------

Door

e64842910	Door hinged on right hand side
-----------	--------------------------------

Measuring

e64844917	Temperature measuring on test specimen (max. 1 sensor) *2
e64842901	Temperature measuring on test specimen switchable by reversible control sensor (max. 1 sensor) *2

Control

e64844920	Digital I/O, 2 inputs and 2 outputs
-----------	-------------------------------------

Special voltages

e60877795	Special voltage 110 V, 1/N, 60 Hz for -40°C ±10 %
e60885388	Special voltage 220 V, 1/N, 60 Hz for -40°C ±10 %
e60885395	Special voltage 240 V, 1/N, 50 Hz for -40°C ±10 %
e60885389	Special voltage 254 V, 1/N, 60 Hz for -40°C ±10 %
e60888815	Ballast, 110 V, for interface converter IEEE 488

Spare parts package

e64842950	Spare parts package for -40 °C
-----------	--------------------------------

Calibration

e64604061	WKD Temperature calibration in test space centre (empty, 1st value)
e64604170	DAkKS Temperature calibration acc. to DAkKS-DKD-R 5-7, Method C

SIMPATI

e64241243	Software package SIMPATI
e64241166	SIMPATI licence
e64241179	Update SIMPATI
e64241233	TCPIP Labview 2013 Driver SIMPAC Climate / Temperature (Ethernet)
e64624947	Socket 220 - 240 V, max. 2 A
e63143193	Ethernet interface cable RJ45, 15 m
e63143014	Interface cable RS 232C, 5 m
e63143016	Interface cable RS 232C, 15 m
e63143052	Interface cable RS 422/RS 485, 5 m
e63143053	Interface cable RS 422/RS 485, 10 m
e63143030	Interface cable RS 422/RS 485, 15 m
e64568909	Converter cable USB to RS 232 C, 100 mm
e64624983	Interface RS 232 C with SIMPAC control
e64241167	Interface RS 422/485 network card for test chamber

Miscellaneous

e64624973 Operating manuals, additional (hardcopy)

We reserve the right to make any technical changes without prior notice.

Your additional equipment.

(Tabellenvorlagen für Sonderoptionen / Modifikationen)

Ordering code: EUR ?

Ordering code: EUR ?

EUR ?