



Incubator

IN160

The incubator I is at home everywhere in the world of research, medicine, pharmaceuticals and food analytics, as well as food chemistry.



The heating of this incubator is optimally tuned for both natural convection and forced air circulation; the fan can also be switched off completely, and valuable chamber loads for research, pharmaceuticals, medicine and food chemistry are warmed up very carefully.

On this page, you can find all the essential technical data on our incubator. Our customer relations team will be pleased to help if you want further information. If you should require a customised special solution, please contact our technical specialists at myAtmoSAFE@memmert.com.

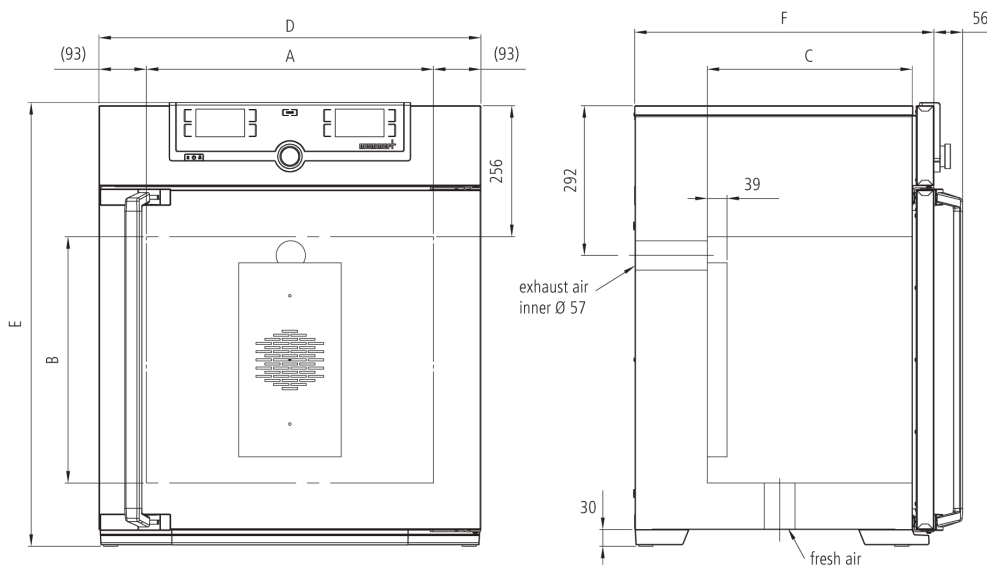

Control of standard components

Control COCKPIT	adaptive multifunctional digital PID-microprocessor controller with high-definition TFT-colour display
Temperature	1 Pt100 sensor DIN class A in 4-wire-circuit
Timer	Digital backwards counter with target time setting, adjustable from 1 minute to 99 days

Temperature

Set temperature range in °C	min. 5°C above ambient up to +80°C
------------------------------------	------------------------------------

resolution of display for setpoint and actual temperature values	0.1°C
---	-------

Control technology

adjustable parameters	temperature (Celsius or Fahrenheit), air flap position, programme time, time zones, summertime/wintertime
Function Setpoint WAIT	the process time does not start until the set temperature is reached
Language setting	German/English/Spanish/French
Calibration	three freely selectable temperature values

Ventilation

natural convection	
Fresh air admixture	adjustment of pre-heated fresh air admixture by air flap control in 10 % steps
Vent	vent connection with restrictor flap

Communication

Programming	AtmoCONTROL software for reading out, managing and organising the data logger via Ethernet interface (temporary trial version can be downloaded). USB stick with AtmoCONTROL software available as accessory (on demand).
Documentation	programme stored in case of power failure

Safety

Temperature control	adjustable electronic overtemperature monitor and mechanical temperature limiter TB, protection class 1 according to DIN 12880 to switch off the heating approx. 20°C above nominal temperature
Autodiagnostic system	for fault analysis

Standard equipment

Door	fully insulated stainless steel door with 2-point locking (compression door lock)
Door	inner glass door
Internals	2 stainless steel grids
Scope of delivery	incl. works calibration certificate for +37°C
Housing	rear zinc-plated steel
Interior	easy-to-clean interior, made of stainless steel, reinforced by deep drawn ribbing with integrated and protected large-area heating on four sides

Stainless steel interior

Dimensions W x H x D in mm	$w_{(A)} \times h_{(B)} \times d_{(C)}$: 560 x 720 x 400 mm
	Volume 161 l
	Max. loading of chamber: 210 kg

Textured stainless steel casing

	$w_{(D)} \times h_{(E)} \times d_{(F)}$: 745 x 1104 x 584 mm
--	---

Electrical data

Voltage	230 V, 50/60 Hz
Electrical load	approx. 1600 W
Voltage	115 V, 50/60 Hz
Electrical load	approx. 900 W

Packing/shipping data

the appliances must be transported upright

Customs tariff number	8419 8998
Country of origin	Federal Republic of Germany
WEEE-Reg.-No.	DE 66812464
	Dimensions approx incl. carton B x H x T: 830 x 1300 x 800 mm
	Net weight approx. 96 kg
	Gross weight carton approx. 122 kg

Standard units are safety-approved and bear the test marks

